

Hardware and Software Module of the KLIPPEL R&D SYSTEM (Document Revision 1.6)

FEATURES

- Add-On for KLIPPEL *SCN Scanning Vibrometer*
- Acoustic measurement of transducers and small devices in half-space (baffle)
- Comprehensive near/ far field radiation data
- Directional characteristics and sound power
- Sound pressure output for almost any point in 3D half-space
- Holographic *Direct Sound Separation*
- Based on Technology of KLIPPEL *NFS – Near Field Scanner System*
- Self-Test capability to ensure accuracy

BENEFITS

- No anechoic room required
- Automated and fast measurements
- Compact measurement setup
- Unifies electrical, mechanical and acoustical testing

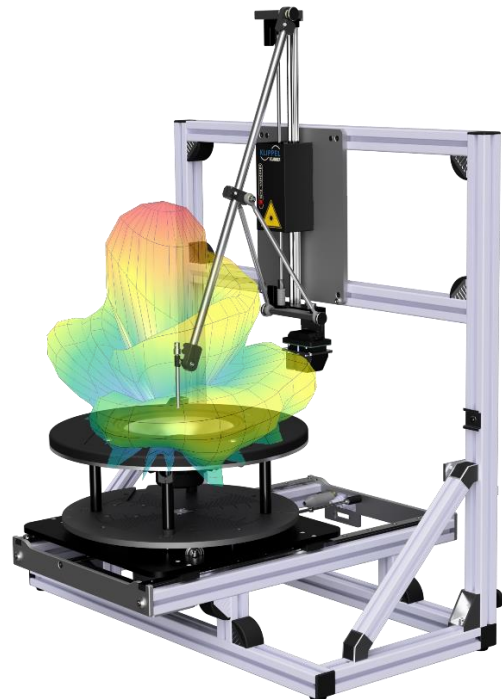

DESCRIPTION

The *SCN Near Field Add-on* enhances the measurement capabilities of the *Klippel SCN Scanning Vibrometer* with automated sound pressure measurements in the near field of transducers and compact audio devices. The radiated direct sound into half-space is determined with high accuracy based on acoustic holographic methods also used in the *Klippel NFS Near Field Scanner System*. Due to the holographic nearfield measurement approach no anechoic room is required for precise measurements. Most relevant transducer measurements can now be done on one hardware in an average office room.

<p>Article numbers</p>	<p>2510-300 SCN Near Field Add-On 2510-004 SCN Vibrometer 2520-013 Near Field Analysis Module (optional) 2520-015 Comparison Module (optional) 2520-016 Complex Data Export (optional) 2520-017 Multi Source Superposition (optional) 2520-019 Holographic Parameter Export (optional)</p>
------------------------	--

CONTENT

1 Overview 3

2 Examples 8

3 Requirements 10

4 Limitations 12

5 Results 14

6 References 15

1 Overview

1.1 Principle	
<p>Target</p>	<p>Target of the <i>SCN Near Field Add-On</i> for the KLIPPEL <i>SCN Scanning Vibrometer</i> is the automated, comprehensive and accurate measurement of radiated direct sound from transducers and audio systems into half space in normal reverberant rooms (non-anechoic environments).</p> <p>This is achieved with the <i>SCN Near Field Add-On</i> by robotic microphone positioning and a measurement method based on acoustic holography.</p> <div data-bbox="427 629 1313 1200" data-label="Diagram"> <pre> graph TD A[Nearfield Measurement] --> B{Measured Sound field} B --> C[Holographic Field Identification] C --> D{Holographic coefficients} D --> E[NFS Visualization] E --> F{Export Interface} F --> G[External Software, EASE, VACS, MATLAB] E --> H[POL Coefficients] </pre> </div> <p>In addition, the <i>Near Field Add-On</i>, together with the feature set of the <i>SCN</i> base unit, enables loudspeaker testing in all three domains, (electrical, mechanical and acoustical) in a single measurement setup.</p>
<p>SCN Scanning Vibrometer</p>	<p>The <i>SCN Scanning Vibrometer</i> is a robotic unit designed for automated measurements of the mechanical vibration of loudspeaker cones and diaphragms.</p> <p>The <i>SCN</i> unit in its base application positions a high precision laser displacement sensor in relation to a loudspeaker DUT for automated measurement of loudspeaker cone vibration and geometry.</p> <div data-bbox="906 1368 1342 1917" data-label="Image"> </div>

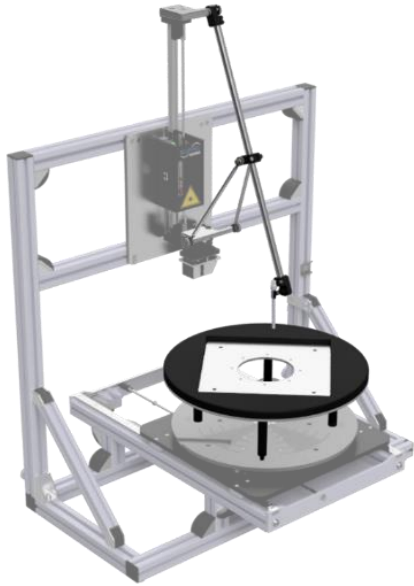
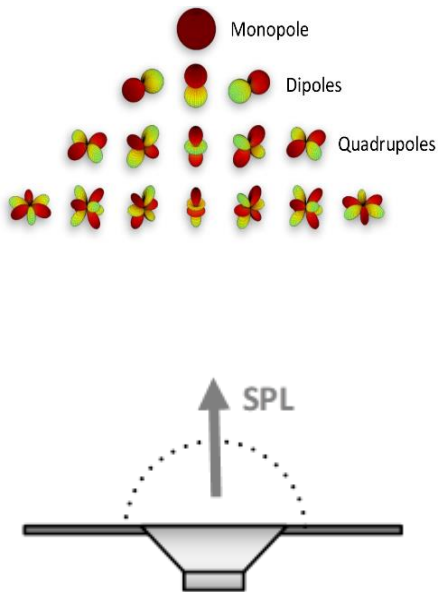
<p>Near Field Add-On</p>	<p>The <i>Near Field Add-On</i> enhances the measurement capabilities of the <i>SCN</i> unit for acoustic nearfield measurements.</p> <p>With the <i>Add-On</i> the <i>SCN</i> robotic hardware can be used for automated positioning of a microphone in the nearfield of loudspeaker DUTs.</p> <p>The <i>Add-On</i> hardware comprises an acoustically transparent microphone sensor arm and a small baffle setup. The baffle setup provides sufficient half-space conditions despite its small size because of the holographic measurement principle. At the same time the baffle is far less prone to mechanical vibrations than large conventional baffles because of its small size and split construction.</p> <p>Transducers are mounted in the baffle with cost effective and easy to manufacture rectangular insert plates. Compact loudspeaker devices can be directly placed on the baffle.</p>	
<p>Holographic Measurement</p>	<p>For comprehensive measurements a holographic measurement process is employed with the <i>SCN Near Field Add-On</i>.</p> <p>The holographic measurement is based on a model fit which provides a full solution for the acoustic wave equation. The model is based on spherical wave components, weighted by spherical harmonics and frequency dependent coefficients.</p> <p>Multiple sound pressure measurements on a plane which envelops a sound source in its near field are used as boundary values for this holographic model. The holographic model describes the radiated acoustic wavefield of the measured sound source in full 3D space.</p> <p>The holographic measurement process is employed in a large-scale application by the KLIPPEL <i>NFS Nearfield Scanner System</i>. The <i>SCN Near Field Add-On</i> enables the holographic measurement in a more compact setup.</p> <p>For more in-depth reference to the holographic measurement procedure see the Klippel NFS documentation and related publications [3].</p>	

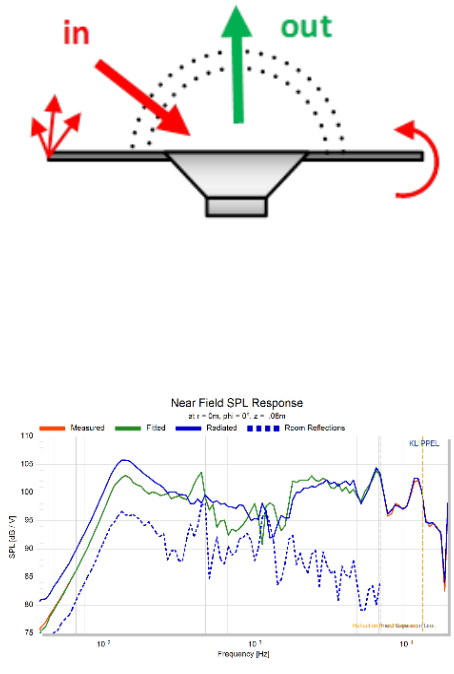
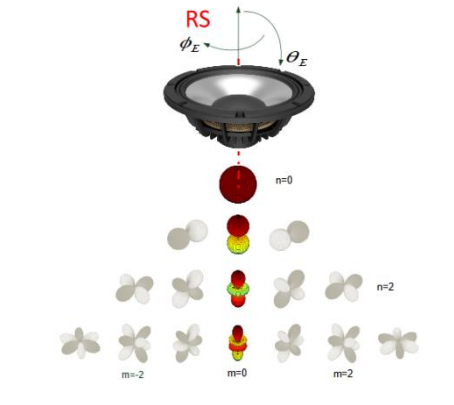
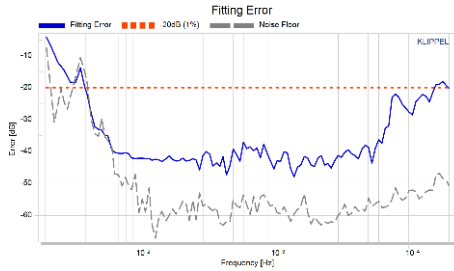
<p>Direct Sound Separation</p>	<p>The capability of the holographic measurement is further improved by basing an advanced model on SPL boundary values taken on two separate enveloping layers around the DUT.</p> <p>This allows separating sound wave components which originate inside the enveloped space from wave components which originate outside of the enveloped space.</p> <p>Holographic measurements with the <i>SCN Near Field Add-On</i> are combined with this <i>Direct Sound Separation</i> and enable full separation of the direct sound from baffle edge diffractions and from the acoustic shortcut around the small baffle. Despite the compact setup, accurate half-space measurements can be taken, which normally require much larger baffles.</p> <p>Influences due to room reflections and standing waves can only be partially separated in measurements with the <i>SCN Near Field Add-On</i>, because the DUT does not remain fully stationary during the measurement process. Due to the nearfield SPL measurement in very close proximity to the DUT these residual room influences only provide a small impact on measurement precision. Therefore, no anechoic room is needed for precise measurements with the <i>SCN Near Field Add-on</i>.</p>	
<p>Exploiting Symmetry</p>	<p>Many loudspeaker DUTs provide geometrical and acoustic symmetry features. For example, typical round transducers provide rotational symmetry over a large bandwidth.</p> <p>These symmetry features are used to simplify the holographic model in order to speed up the measurement process.</p> <p>The rotational symmetry of round DUTs reduces the measurement time by up to 98% and enables detailed directivity measurements with high spatial resolution in approximately 5 minutes.</p>	
<p>Self-Test Capability</p>	<p>The holographic measurement principle is based on a model fit. Therefore, a very small and usually negligible residual discrepancy between the model-fit and the measurement remains.</p> <p>Based on redundancy in the measurement this discrepancy is monitored and assessed by error measures in order to assure measurement validity and precision.</p>	

1.2 Results		
Fundamental Frequency Response	<p>Frequency response at almost any point in half space.</p> <p>From simple on axis frequency responses normalized to 1 m at 1 W, to full custom responses at multiple points for both near and far field.</p> <p>Automatically generated <i>Spinorama</i> charts according to CEA 2034 [1] for transducers and in-wall speakers are also provided.</p>	
Sound Power Response	<p>Meaningful single value representation of total sound radiation.</p> <p>Especially valuable for sound sources where the listener is located in the diffuse sound field.</p>	
Directivity Index	<p>Meaningful single value representation of source directivity.</p>	
Polar Plots	<p>Polar representation of directivity at single or multiple frequencies.</p>	
Contour Plots	<p>Contour Plots for comprehensive directivity analysis which plot the sound pressure output over one angular dimension at a given distance for the full frequency range.</p>	
Balloon Plots	<p>Balloon Plots for full spatial imaging of sound pressure output at single frequencies. Available for both magnitude and phase imaging.</p>	

<p>Nearfield SPL Distribution</p> <p>Optional module required: Near Field Analysis Module</p>	<p>SPL distribution in close proximity of the DUT plotted on configurable planes.</p> <p>Valuable information for sound sources where the listener is located in the near field.</p>	<p>Near Field - Sound Pressure Distribution f = 700 Hz</p> <p>44 47 50 53 56 59 62 65 68 71 74 77 80 83 86 89 92 94</p> <p>Sound Pressure Level (dB (pA))</p>
<p>Nearfield Wave Propagation</p> <p>Optional module required: Near Field Analysis Module</p>	<p>Wave propagation in close proximity to the DUT.</p> <p>Valuable information for sound sources where the listener is located in the near field.</p>	<p>Near Field - Sound Wave Distribution f = 700 Hz</p> <p>42 30 20 10 0 10 20 30 42</p> <p>Amplitude Range %</p>

2 Examples

2.1 Woofer in Baffle

The directivity and basic data of transducers is typically measured under half space condition emulated by large baffle setups in anechoic rooms. The half space condition even with very large IEC baffle setups according to IEC 60268-5 [2] are only an approximation. Influences on the measurement due to components from the acoustic shortcut and baffle edge diffractions remain. Large baffles are also prone to mechanical vibrations which emit parasitic sound and also disturb the measurement results.

Due to the holographic measurement approach with *Direct Sound Separation* the *SCN Near Field Add-On* provides accurate not just approximated half space conditions.

This example shows a baffle directivity measurement of a small woofer performed with the *SCN Near Field Add-On*. The transducer is mounted in the Add-On baffle, operated in free air and measured in the front half-space. The measurement is performed in an ordinary office room.

The round transducer geometry is used for rotational symmetrical simplification in the holography to speed up the measurement process. Only 30 measurement points are needed to provide an equivalent result to a 500-point full scan. The measurement is done in 5 minutes.

Key results are comprehensive far field directivity datasets, accurate low frequency response despite the measurement in a normal room and negligible influences from to the baffle.

A comparison with a traditional baffle measurement according to IEC 60268-5 [2] in an anechoic room shows the superiority of the holographic measurement principle and the minimalistic baffle setup of the *SCN Add-On*.

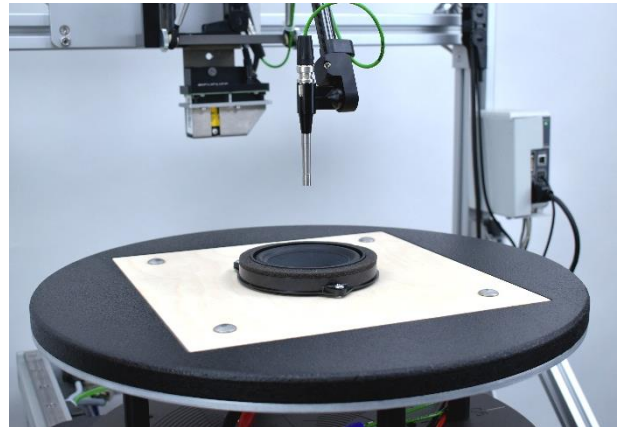

Far Field - Contour Plot

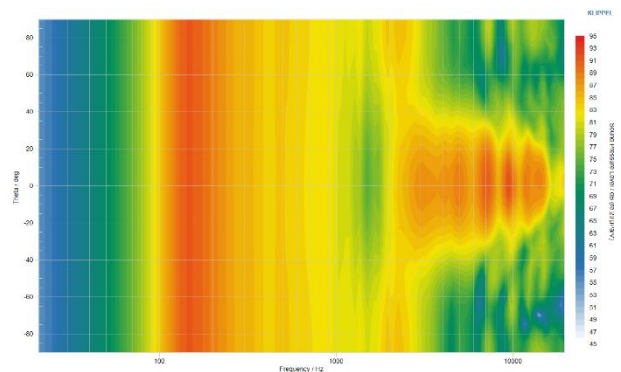

Far Field - Sensitivity

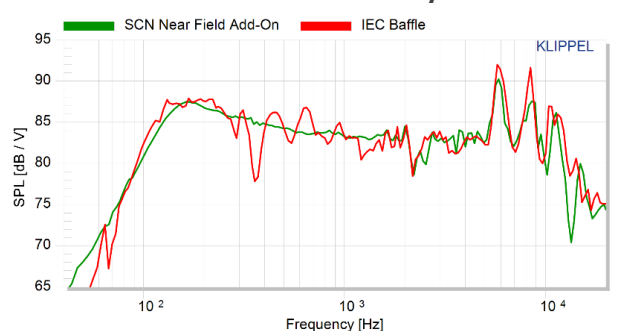

2.2 Compact Audio Device

A half-space setup is the typical operating condition of compact loudspeaker devices like wireless multimedia speakers, smart speakers or even cellphones used as a stationary loudspeaker because these devices are usually placed on a larger structure, typically a table. These devices should therefore be measured in such a setup in order to provide meaningful data close the experience of the end user.

This example shows a measurement of a small loudspeaker device in half-space condition with the *SCN Near Field Add-On*.

The device is positioned on the add-on baffle. A comprehensive full scan of the device with 400 measurement points is done in approximately 1 hour. The measurement is performed in a small office room.

Key results are accurate frequency- and sound power response of the device in its typical half-space operating condition. Again, accurate data is acquired despite the very small baffle and the measurement in a normal room.

The optional *Near Field Analysis Module* further enables detailed evaluations directly in the near field in which the listener is often located.

(For measurements of wireless devices like Bluetooth speakers an [asynchronous measurement](#) is required and an additional 2nd microphone is needed.)

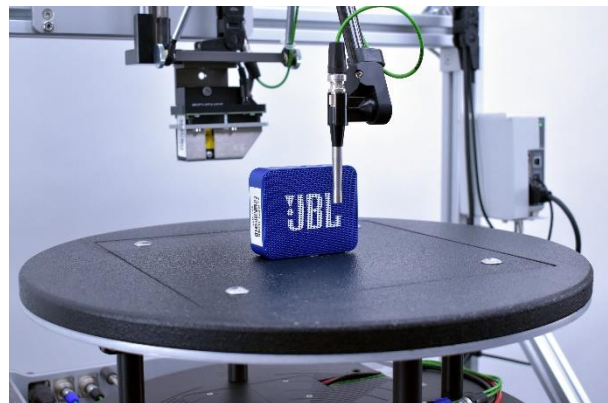

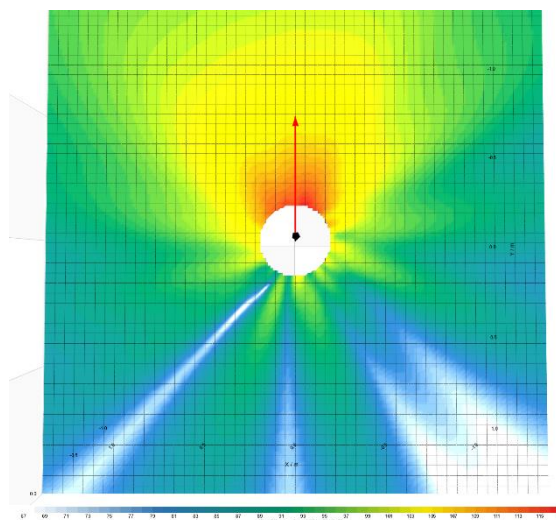

Near Field – Sound Pressure Distribution

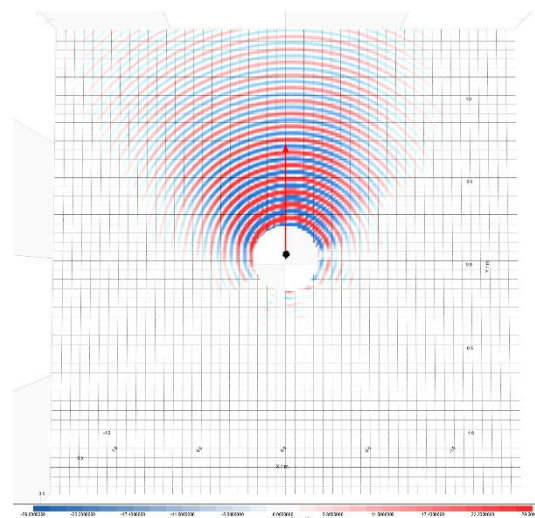

Near Field – Sound Wave Propagation



3 Requirements

3.1 Hardware and Software			Spec
SCN Near Field Add-on		<p>Add-On hardware components for <i>SCN Scanning Vibrometer</i> to enable acoustic measurements in half-space and software components for holographic measurement and evaluation.</p> <p>(New purchases of SCN are shipped as Multi Scanning Workbench already including SCN Near Field Add-On Hardware components. Software and sensors still sold separately.)</p>	C12
SCN Hardware		<p><i>SCN Scanning Vibrometer</i> and <i>Motor Control</i> for automated DUT positioning.</p> <p>(New purchases of SCN are shipped as Multi Scanning Workbench already including SCN Near Field Add-On Hardware components)</p>	C5
KA3 / DA2		<i>Klippel Analyzer 3</i> or <i>Distortion Analyzer 2</i> hardware	H3 H1
Microphone		<p>Free field measurement microphone, with small cartridge size of max. ¼".</p> <p>Recommended microphone <i>GRAS 40PP</i>, cost efficient ¼" free field microphone.</p> <p>(Additional 2nd microphone required for measurements of wireless devices.)</p>	A4
TRF		TRF Transfer Function Measurement software module for measurement and data acquisition.	S7
(Amplifier)		Optional external Amplifier with a flat frequency response over the desired measurement bandwidth. Not necessary when an internal <i>KA3 Amp Card</i> is used.	H6 Amp
(Near Field Analysis)		Optional software module for advanced visualization and analysis features directly in the near field	C8

(Complex Export)		Various optional export interfaces for complex data export or direct export of holographic coefficients. (VACS, EASE, CLF, Matlab, Scilab, Coefficients ...)	C8
(Comparison)		Optional software module for advanced comparison between two measured sources.	C8
(Multi Source Superposition)		Optional software module for superposition of multiple measured sources and evaluation of their total generated sound field.	C8

3.2 Environment

Room	<p>For measurements with the <i>SCN Near Field Add-On</i> no anechoic room is required.</p> <p>For maximum measurement precision a reflection-free distance between the <i>Add-on Baffle</i> and the next large room boundary (wall, ceiling, floor) of 10 times the holographic measurement grid radius is recommended. For DUTs up to the maximum supported size this results in a recommended distance of 1.5 m to the walls and ceiling. To the floor a distance of 1m is sufficient.</p> <p>The ideal setup location for the <i>SCN Near Field Add-On</i> is on a small table or 19" rack in the center of a room with a size of at least 3m x 3m x 2.5m.</p> <p>If a smaller room has to be used, acoustic absorbers can be applied to walls and ceiling to increase measurement precision. Relatively thin absorbers with a thickness of 50mm and an absorption coefficient larger than 0.5 from 500 Hz up are sufficient.</p> <p>A smaller reflection-free distance without additional absorbers can also be used if only very small DUTs (< 50 mm) are measured.</p>
------	--

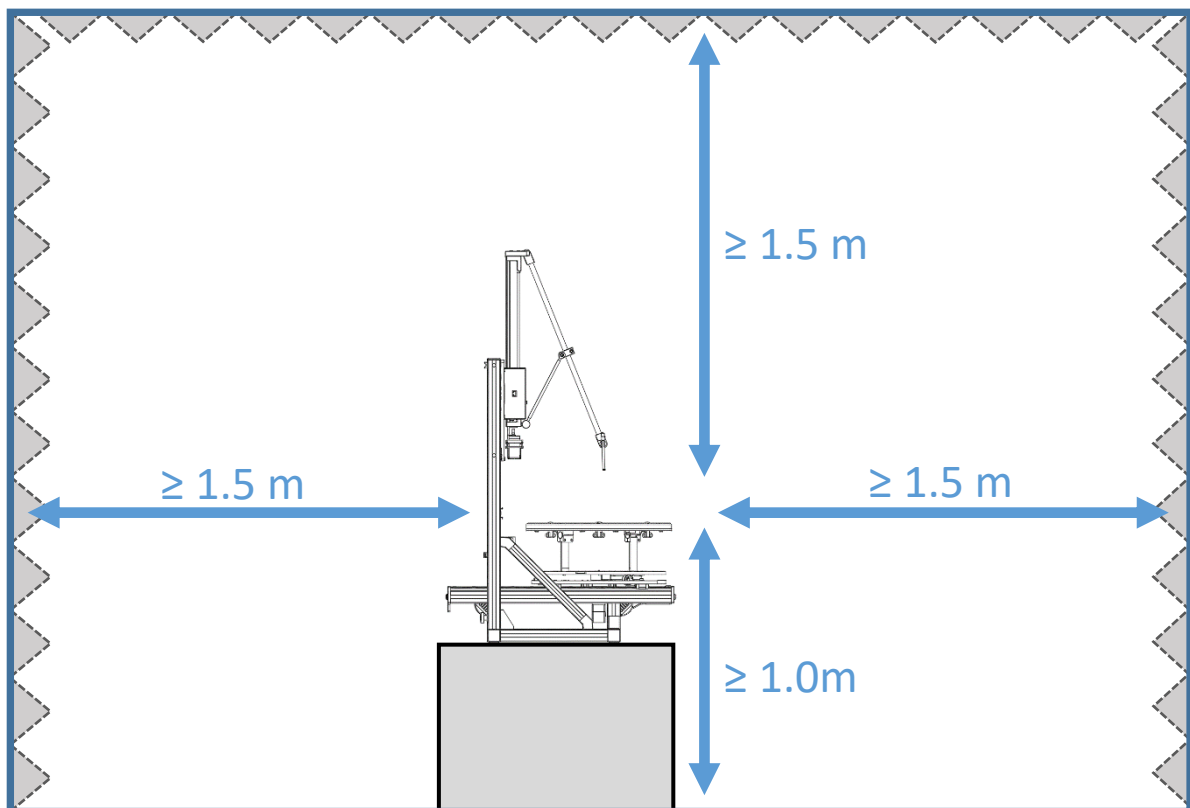

Acoustic absorbers on walls are optional for maximum measurement precision with even smaller reflection free distances.

4 Limitations

4.1 Measurement Precision

Parameter	Symbol	Min.	Typ.	Max.	Unit
Free field deviation*		± 0.5	± 1.0	-	dB

*Deviation of holographic measurement results from ideal half space free field conditions. Deviation slightly dependent on room and setup position, see 3.2 for setup recommendations.

4.2 Physical Limits - Device Under Test

Parameter	Symbol	Min.	Typ.	Max.	Unit
Transducer diameter	D	-	-	300**	mm
Baffle hole diameter	Dh	-	-	250	mm
Transducer depth*	H	-	-	150	mm
Compact device diameter	Dd	-	100	280***	mm
Compact device height	Hd	-	100	140***	mm
Total mass of DUT	m	-	-	25	kg

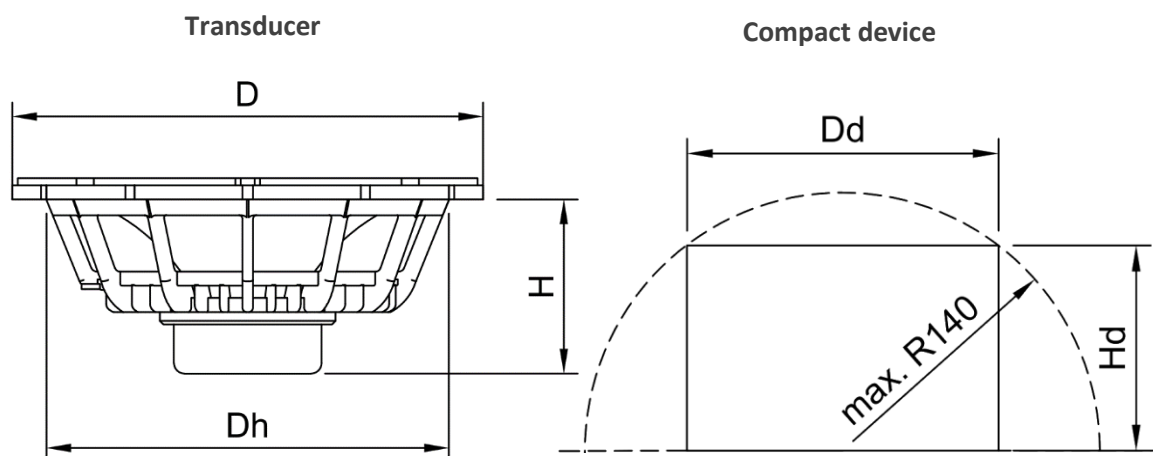

*Depth of the transducer protruding through the baffle into the rear half-space.

**Transducer diameter on older SCN units (Rev. <= 1.6) is limited to 210 mm. To reach full 300 mm transducer DUT size on older SCN units the microphone boom of the SCN Near Field Add-On can be shortened.

***Maximum diameter and height of compact devices is linked. Device must fit into a hemisphere with a maximum radius of 140 mm. (On older SCN units (Rev. <= 1.6) the same limitation as for transducers applies** and the maximum compact device hemisphere size is reduced to 95 mm. To reach the full hemisphere size on older SCN units the microphone boom of the SCN Near Field Add-On can be shortened.)

4.3 Physical Limits - Hardware Dimension

Physical dimensions

Maximum height of SCN unit is extended by 20 mm when the add-on is installed. See following drawing for reference:

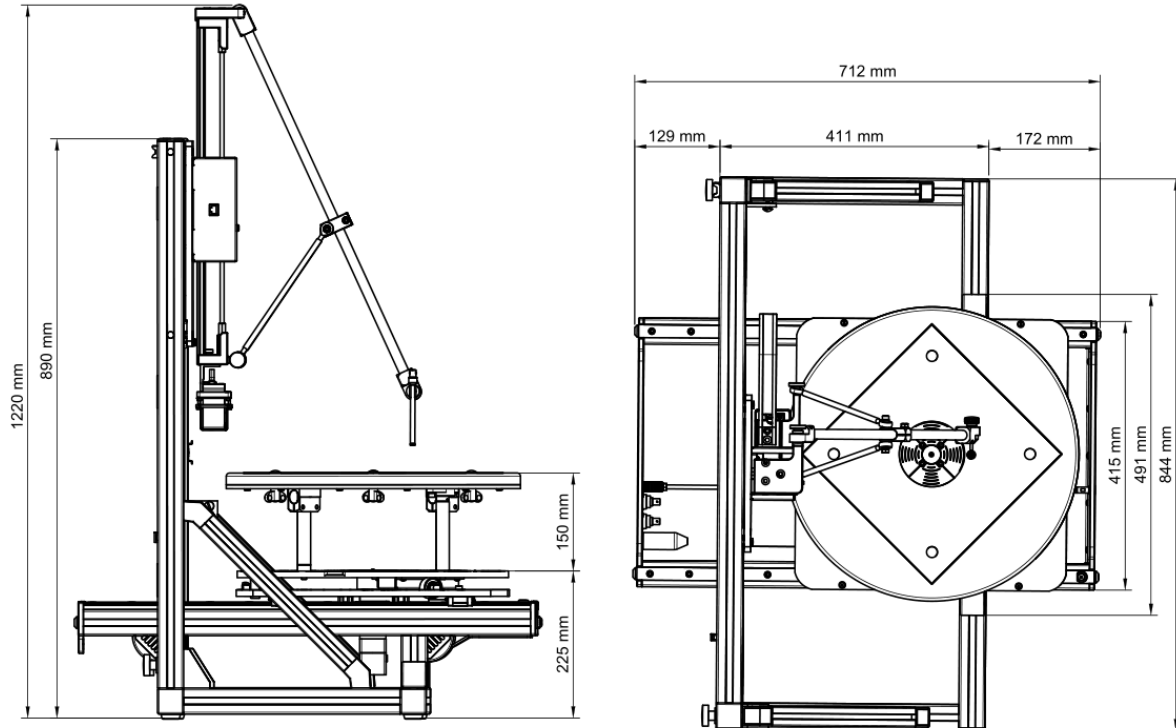

4.4 Software Limits – Module Setup Parameters

Parameter	Min.	Typ.	Max.	Unit
Holographic Frequency Resolution	6	20	48	points per octave
Frequency Range*	>0	20-20k	87.2k**	Hz
Number of Measurement Points	10	30	1000	-
DUT diameter	10	-	300	mm
DUT height	10	-	140	mm
Safety Distance to Baffle	5	10	-	mm
Grid Type / Symmetry	Full Scan: baffle symmetry Line Scan: baffle and rotational symmetry			
DUT Type	Transducer: transducers or in-wall loudspeaker devices Device: compact loudspeaker devices			

* Limitation of KLIPPEL Analyzer Hardware. The practical usable frequency range is also limited by the bandwidth of the used measurement microphone.
 ** Maximum frequency range with KLIPPEL Distortion Analyzer (DA2) is 43.6 kHz.

5 Results

Result/Feature	SCN Near Field Add-On	Optional Modules Needed		
		Near Field Analysis Module	NFS - Export Module	Multi Source superposition Module
FF – Far Field NF – Near Field				
Automated Near Field Measurement in Half Space (2π)	x			
FF SPL Response	x			
FF Polar Plot	x			
FF Directivity Balloon	x			
FF Contour Plot	x			
FF Radiated Sound Power	x			
FF Export Amplitude	x			
CEA 2034 Spinorama-Charts	x			
IEC 62777		x		
FF Export Amplitude/Phase Data (EASE)			x	
NF SPL Distribution		x		
NF Wave Propagation		x		
NF SPL Response		x		
FF Phase Response	x			
FF Phase Balloon	x			
FF Group Delay	x			
FF Impulse Response	x			
Holography Parameter Export			x	
Comparison of all Far Field Plots	x			
Superposition of multiple sound sources				x

6 References

6.1 Related Modules	NFS - Nearfield Scanner System SCN - Scanning Vibrometer	
6.2 Standards	[1]. ANSI/CEA-2034: "Standard Method of Measurement for In-Home Loudspeakers", 2013, Consumer Electronics Association [2]. IEC 60268-5: "Sound system equipment – Part 5: Loudspeakers", 2003, International Electrotechnical Commission	
6.3 Publications	[3]. " Holographic Nearfield Measurement of Loudspeaker Directivity ", 2016, KLIPPEL GmbH	
6.4 Patents	Germany	102013000684
	USA	14/152,556
	China	2014100795121

Find explanations for symbols at:

<https://www.klippel.de/know-how/literature.html>

Last updated: October 20, 2021

Designs and specifications are subject to change without notice due to modifications or improvements.

